

# INSTRUCTION MANUAL

## RA 60 SERIES RACK ADAPTER

RA 60, RA 62, AND RA 63

KEPCO INC.  
An ISO 9001 Company.

### MODEL RA 60 SERIES RACK ADAPTER

ORDER NO.

REV. NO.

#### IMPORTANT NOTES:

- 1) This manual is valid for the following Model and associated serial numbers:

MODEL	SERIAL NO.	REV. NO.
-------	------------	----------

- 2) A Change Page may be included at the end of the manual. All applicable changes and revision number changes are documented with reference to the equipment serial numbers. Before using this Instruction Manual, check your equipment serial number to identify your model. If in doubt, contact your nearest Kepco Representative, or the Kepco Documentation Office in New York, (718) 461-7000, requesting the correct revision for your particular model and serial number.
- 3) The contents of this manual are protected by copyright. Reproduction of any part can be made only with the specific written permission of Kepco, Inc.

Data subject to change without notice.

©2005, KEPCO, INC  
P/N 243-0909



KEPCO, INC. ● 131-38 SANFORD AVENUE ● FLUSHING, NY. 11352 U.S.A. ● TEL (718) 461-7000 ● FAX (718) 767-1102  
email: [hq@kepcopower.com](mailto:hq@kepcopower.com) ● World Wide Web: <http://www.kepcopower.com>



## Declaration of Conformity

Application of Council directives: **73/23/EEC (LVD)**  
**93/68/EEC (CE mark)**

Standard to which Conformity is declared:

**EN60950-1:1992 +A1: 1993 + A2 : 1993** (Safety of information technology equipment,  
including electrical business equipment)

Manufacturer's Name and Address: **KEPCO INC.**  
**131-38 SANFORD AVENUE**  
**FLUSHING, N.Y. 11352 USA**

Importer's Name and Address:

**REPRESENTATIVE COPY**

Type of Equipment: **Rack Adapter**

Model No.: **[PRODUCT MODEL NUMBER]**

Year of Manufacture:

I, the undersigned, declare that the product specified above, when used in conjunction with the conditions of conformance set forth in the product instruction manual, complies with the requirements of the Low Voltage Directive 73/23/EEC, which forms the basis for application of the CE Mark to this product.

Place: **KEPCO Inc.**  
**131-38 Sanford Ave.**  
**Flushing, N.Y.11352 USA**

Saul Kupferberg  
(Full Name)

Date: \_\_\_\_\_

VP OF SALES  
(position)

## **Conditions of Conformance Rack Adapter products (EN60950)**

When this product is used in applications governed by the requirements of the EEC, the following restrictions and conditions apply:

1. For European applications, requiring compliance to the Low Voltage Directive, 73/23/EEC, this Rack Adapter is considered a component, designed for "building in". Because it is incomplete in construction, the end product enclosure must provide for compliance to any remaining electrical safety requirements and act as a fire enclosure. (EN60950, CL.2.1, 2.7, 3.3, 4.3 and 4.4.5).
2. This Rack Adapter is designed for stationary installation, with mains power applied via a detachable power supply cord or via direct wiring to a source power terminal block.
3. This Rack Adapter, when properly installed, is considered a Class 1 (earthed) product, and as such depends upon proper connection to protective earth for safety from electric shock. (EN60950 Cl. 2.5)
4. This product is intended for use as part of equipment meant for an Information Technology Equipment environment. It is designed to operate from single phase, three wire TN power systems. This equipment must be installed within a suitably wired equipment rack, utilizing a three wire (grounded) mains connection. See wiring section of this manual for complete electrical wiring instructions.
5. When fitted with the appropriate power supplies, this product may have secondary output circuits that are considered hazardous, and which exceed 240 VA at a potential of 2V or more.
6. The output wiring terminals of this power supply have not been evaluated for field wiring and, therefore, must be properly configured by the end product manufacturer prior to use.
7. For complete circuit protection of the end product, as well as the building wiring, it is required that a primary circuit protection device be fitted to the branch circuit wiring. (EN60950 Cl. 2.5).
8. When installed with other components and/or power supplies, hazardous voltages may be present within the equipment during normal operation. All operator adjustments are made via externally accessible switches, controls and signal lines as specified within the individual power supply operating instructions. There are no user or operator serviceable parts within this product enclosure. Refer all servicing to qualified and trained Kepco service technicians.

# SAFETY INSTRUCTIONS

## 1. Installation, Operation and Service Precautions

This product is designed for use in accordance with EN 60950 and UL 1950 for Installation Category 2, Pollution Degree 2. Hazardous voltages are present within this product during normal operation. The product should never be operated with the cover removed unless equivalent protection of the operator from accidental contact with hazardous internal voltages is provided



There are no operator serviceable parts or adjustments within the product enclosure. Refer all servicing to trained service technician.



Source power must be removed from the product prior to performing any servicing.



This product is factory-wired for the nominal a-c mains voltage indicated on the rating nameplate located adjacent to the source power connection on the product's rear panel.

## 2. Grounding

This product is a Class 1 device which utilizes protective earthing to ensure operator safety.



The PROTECTIVE EARTHING CONDUCTOR TERMINAL must be properly connected prior to application of source power to the product (see instructions on installation herein) in order to ensure safety from electric shock.



PROTECTIVE EARTHING CONDUCTOR TERMINAL - This symbol indicates the point on the product to which the protective earthing conductor must be attached.



EARTH (GROUND) TERMINAL - This symbol is used to indicate a point which is connected to the PROTECTIVE EARTHING TERMINAL. The component installer/ assembler must ensure that this point is connected to the PROTECTIVE EARTHING TERMINAL.

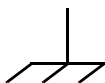

CHASSIS TERMINAL - This symbol indicates frame (chassis) connection, which is supplied as a point of convenience for performance purposes (see instructions on grounding herein). This is not to be confused with the protective earthing point, and may not be used in place of it.

## 3. Electric Shock Hazards

This product outputs hazardous voltage and energy levels as a function of normal operation. Operators must be trained in its use and exercise caution as well as common sense during use to prevent accidental shock.



This symbol appears adjacent to any external terminals at which hazardous voltage levels as high as 500V d-c may exist in the course of normal or single fault conditions.



This symbol appears adjacent to any external terminals at which hazardous voltage levels in excess of 500V d-c may exist in the course of normal or single fault conditions.



# TABLE OF CONTENTS

SECTION		PAGE
<b>SECTION 1 - INTRODUCTION</b>		
1.1	Scope of Manual .....	1-1
1.2	General Description.....	1-1
1.3	Options .....	1-1
1.4	Accessories .....	1-4
<b>SECTION 2 - INSTALLATION</b>		
2.1	Unpacking and Inspection .....	2-1
2.2	Rack Adapter Keying Instructions .....	2-1
2.3	Terminations.....	2-2
2.4	Source Power Requirements .....	2-2
2.5	Cooling .....	2-2
2.6	Installation .....	2-3
2.6.1	Mounting Ear Installation .....	2-5
2.7	Wiring Instructions.....	2-5
2.7.1	Safety Grounding.....	2-6
2.7.2	Source Power Connections .....	2-6
2.7.3	Source Power Configurations .....	2-6
2.7.3.1	A-C Source Power, Single Phase .....	2-7
2.7.3.2	A-C Source Power, Three Phase.....	2-7
2.7.3.3	D-C Source Power .....	2-8
2.7.4	Control Signal Connections .....	2-8
2.7.5	Output Load Connections.....	2-8
2.7.5.1	Parallel/Redundant Operation.....	2-9
2.7.5.2	Series/Independent Operation .....	2-9
2.8	Shipping .....	2-9

# LIST OF FIGURES

FIGURE	TITLE	PAGE
1-1	Series RA 60 Rack Adapter .....	iv
1-2	Mechanical Outline Drawing, Series RA 60 Rack Adapter.....	1-2
2-1	Key Pin Location .....	2-1
2-2	Rear Panel Connections .....	2-2
2-3	Mounting Dimensions .....	2-3
2-4	Set-back Dimensions .....	2-4
2-5	Mounting Ear Installation.....	2-5
2-6	Single Phase A-C/D-C Source Power Wiring.....	2-7
2-7	Three Phase Delta A-C Source Power Wiring .....	2-7
2-8	Three Phase Wye A-C Source Power Wiring.....	2-8



# LIST OF TABLES

TABLE	TITLE	PAGE
1-1	Rack Adapter Options .....	1-4
1-2	Accessories .....	1-4
2-1	Equipment Supplied .....	2-1

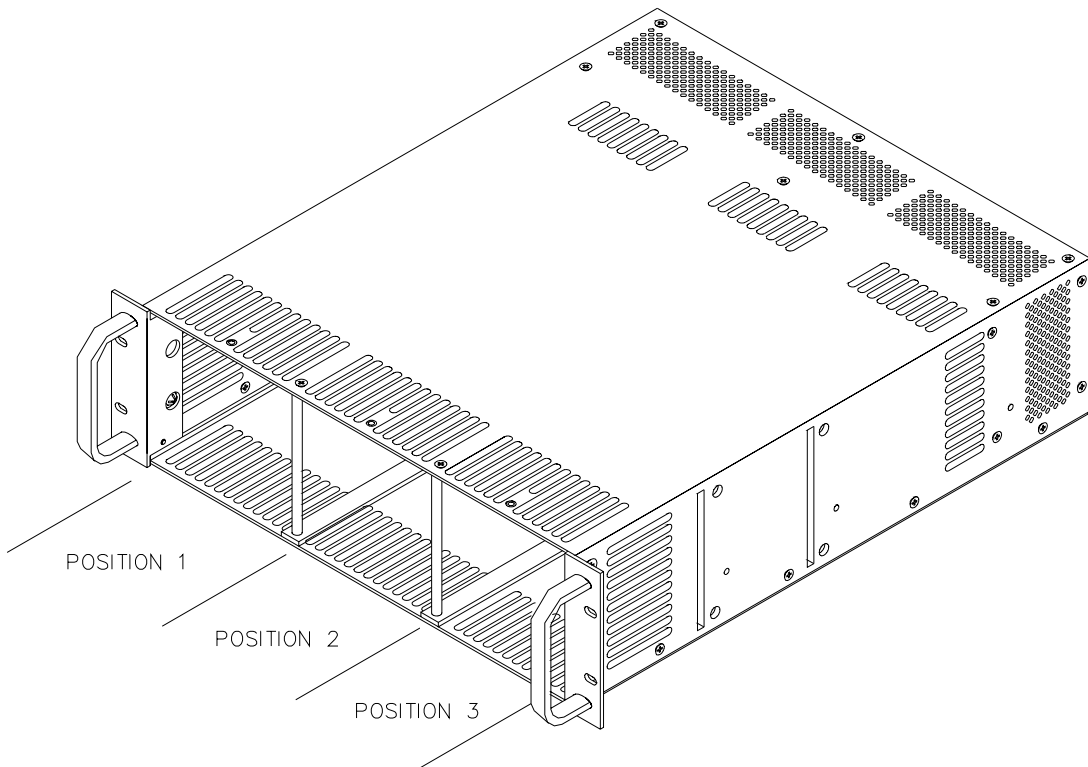

3040511

**FIGURE 1-1. SERIES RA 60 RACK ADAPTER**

## SECTION 1 - INTRODUCTION

### 1.1 SCOPE OF MANUAL

This manual contains instructions for the installation and operation of RA 60 Series plug-in rack adapters (Figure 1-1), including RA 60, RA 62 and RA 63, used with HSP Series power supplies, manufactured by Kepco, Inc., Flushing, New York, U.S.A.

### 1.2 GENERAL DESCRIPTION

Kepco Series RA 60 rack adapters are specifically designed for the installation of Kepco HSP Series Power Supplies into 19-inch, 23-inch and 24-inch EIA standard equipment racks. Each rack adapter accommodates from one to three HSP power supplies. An internal plate assembly mounts connectors which interface directly with the power and signal connectors of HSP series power supplies, permitting pluggable insertion and extraction, while a separate external rear panel contains the fixed power and signal connections. Separate source power, signal, and load terminations are provided for each of the three power supply mounting positions. Internal power output configurations differ for the three models as follows:

- RA 60 Output power connections for all three positions are internally connected for parallel/redundant applications.
- RA 62 Output power connections for positions 1 and 2 are internally paralleled, position 3 is independent from the other two.
- RA 63 Output power connections not connected internally, all three positions are independent of each other

External dimensions and mounting provisions are identical for all Series RA 60 Rack Adapter models All mechanical and electrical specifications are contained in the outline drawing: Figure 1-2.

Each rack adapter occupies 5.22 inches (132.5 mm) of vertical space and has a maximum depth protrusion of 21 inches measured from the mounting surface of the "ear" brackets. Mounting positions are provided for flush mount as well as  $\frac{1}{4}$  setback and  $\frac{1}{2}$  setback (notched mounting ears required). All rack adapters are shipped with mounting ears for flush mounting in EIA 19-inch equipment racks. The rack adapters can be fitted with optional blank filler panels in both  $\frac{1}{3}$  and  $\frac{2}{3}$  dimensions if the full complement of three power supplies is not utilized.

### 1.3 OPTIONS

Series RA 60 Rack Adapters are available for 19-inch, 23-inch, and 24-inch wide racks. Table 1-1 below describes the model options available with Series RA 60 rack adapters.

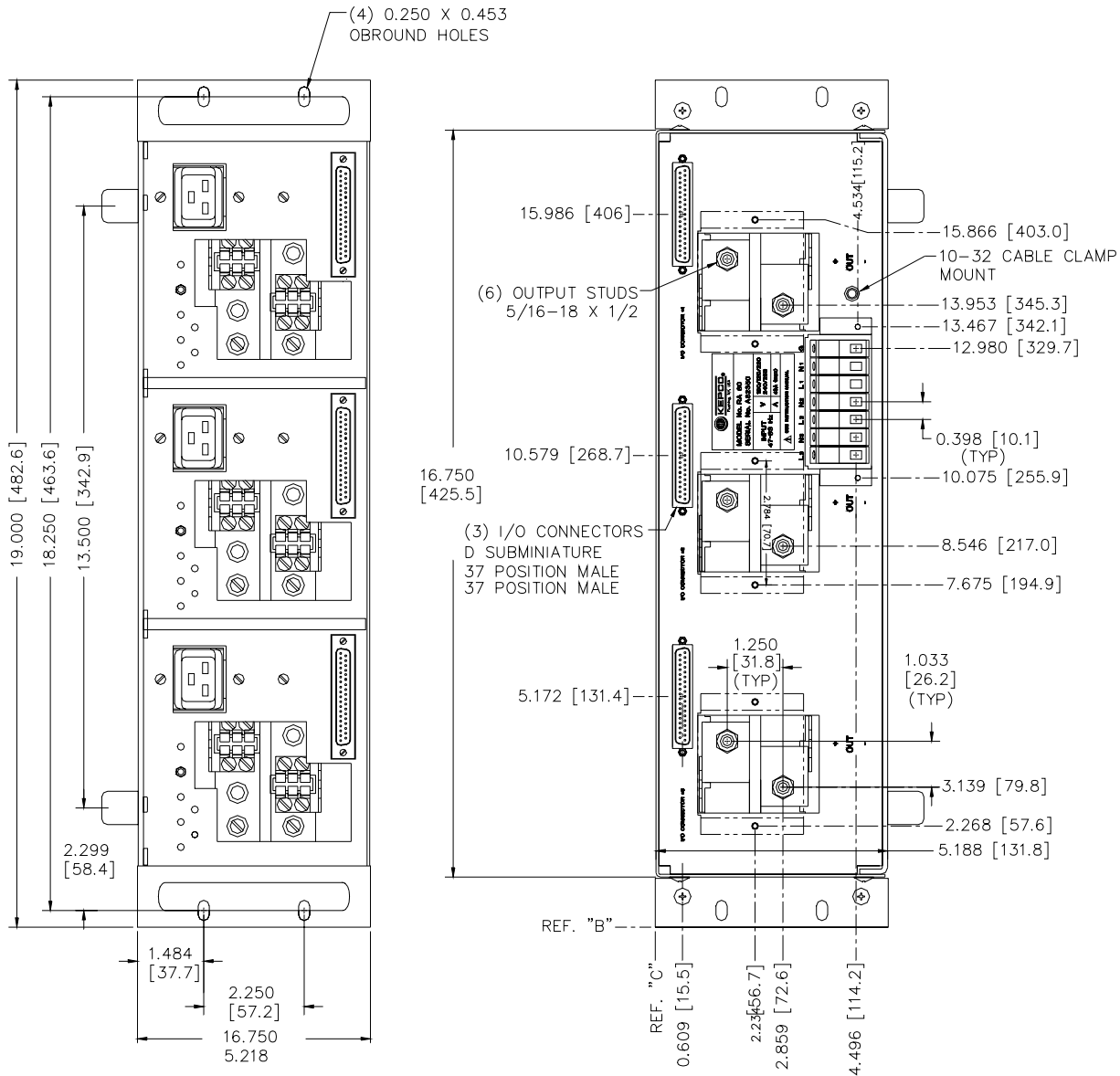

NOTES:

1. MATERIAL:
  - A) CHASSIS STEEL CRS #11 GAGE
  - B) COVER, BACKPLATE, INTERMEDIATE PLATE STEEL CRS #16 GAGE
2. FINISH:
  - A) CHASSIS & BACK COVER: YELLOW IRIDITE.
  - B) FRONT PANEL & ANGLE BKT: KEPKO GRAY,
  - C) COVER: KEPKO CHARCOAL
3. RACK OR CABINET MOUNTING: REMOVE (4) ALUMINUM FEET
4. OPTIONAL MOUNTING BRACKETS (128-1714) SET-BACK,
  - 23" CABINET EXTENSION BRACKET 1281776 RELAY RACK
  - 23" CABINET EXTENSION & SETBACK BRACKET (1281736)
  - 24" CABINET EXTENSION & SETBACK BRACKET (1281827) RELAY RACK E1A-RS310-C STANDARD.
5. DIMENSIONS IN PARENTHESES ARE IN MILLIMETERS.
6. TOLERANCES:
  - A) BETWEEN MOUNTING HOLES:  $\pm 1/64$  ( $\pm 0.4$ )
  - B) ALL OTHER DIMENSIONS:  $\pm 1/32$  ( $\pm 0.8$ ), EXCEPT AS NOTED.
7. FOR MOUNTING SLIDES USE JONATHAN SLIDES 110QD-18-1(KEPCO 108-0318) WITH RETMA BRACKETS JONATHAN SPO440 (KEPCO 128-1849) MAX TRAVEL 20". BRACKETS (128-1849) MUST BE MOUNTED TO CABINET SECTION OF SLIDE (108-0318) SO THAT CABINET SECTION DOES NOT COVER LOUVERS WHEN RACK ADAPTER IS POSITIONED ENTIRELY WITHIN CABINET. MOUNT SLIDES TO RACK ADAPTER USING (4) 10-32 X 0.437" PAN HEAD SCREWS (KEPCO # 101-0437).

3010134

**FIGURE 1-2. MECHANICAL OUTLINE DRAWING, SERIES RA 60 RACK ADAPTER (SHEET 1 OF 2)**

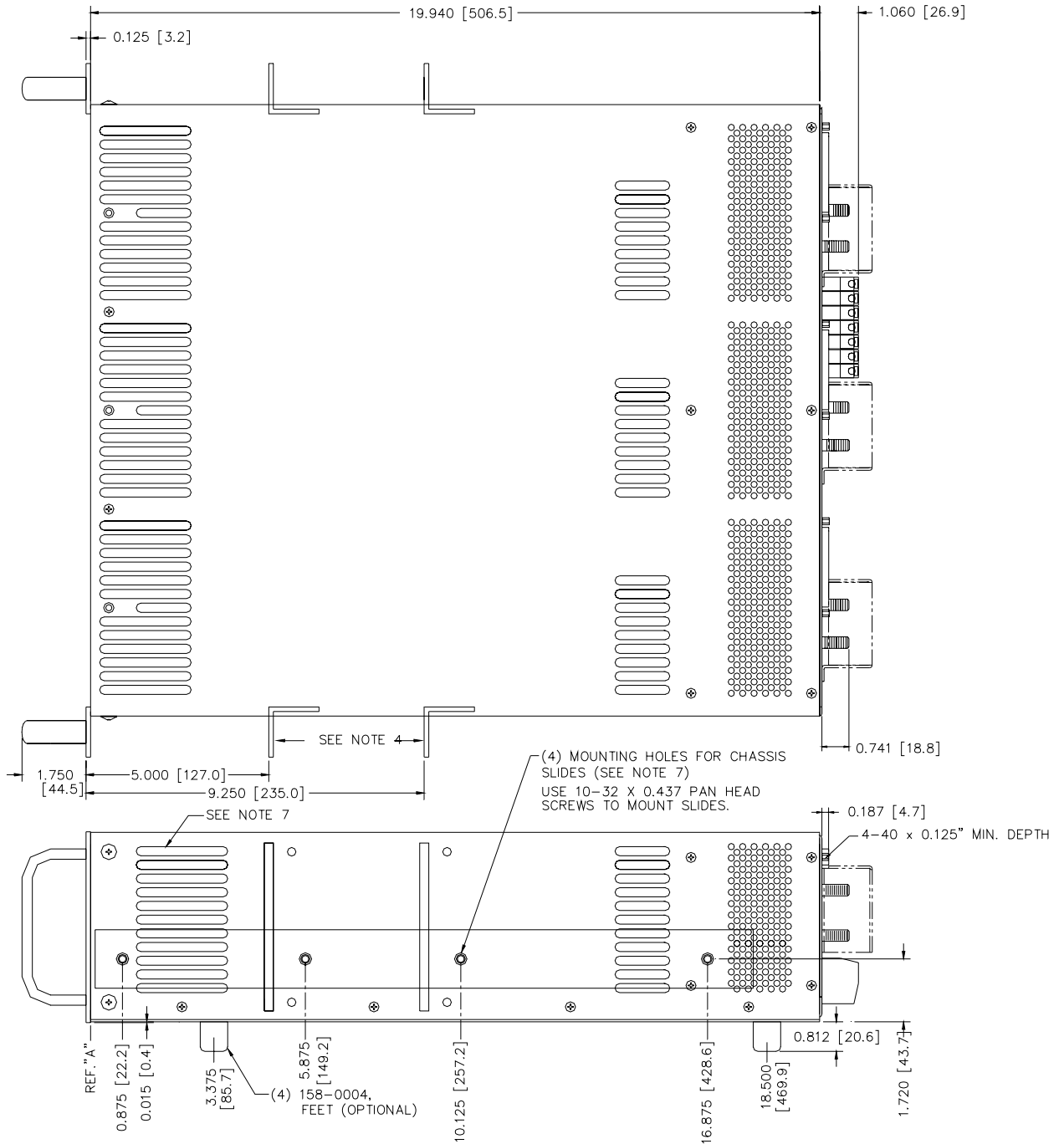

3010134

**FIGURE 1-2. MECHANICAL OUTLINE DRAWING, SERIES RA 60 RACK ADAPTER (SHEET 2 OF 2)**

**TABLE 1-1. RACK ADAPTER OPTIONS**

MODEL	DESCRIPTION
RA 60, RA 62, RA 63	Accommodates up to three HSP Power Supplies in a 19-inch rack. Used for hot-swap independent, series or parallel/redundant applications where HSPs are plugged in to the rack adapter and can be easily removed and inserted without affecting system operation.
RA 60-23E, RA 62-23E, RA 63-23E	Same as RA 60, RA 62, RA 63 except mounting ears are wider to accommodate a 23-inch rack.
RA 60-24E, RA 62-24E, RA 63-24E	Same as RA 60, RA 62, RA 63 except mounting ears are wider to accommodate a 24-inch rack.

## 1.4 ACCESSORIES

Accessories for HSP Power Supplies are listed in Table 1-2.

**TABLE 1-2. ACCESSORIES**

ACCESSORY	PART NUMBER	USE
MOUNTING BRACKETS (NOTCHED)	128-1714	Used to mount RA 60, RA 62, or RA 63 in 19-inch rack using "set back" position (see Figure 2-4).
	128-1736	Used to mount RA 60, RA 62, or RA 63 in 23-inch rack using "set back" position (see Figure 2-4).
	128-1827	Used to mount RA 60, RA 62, or RA 63 in 24-inch rack for both flush and "set back" positions (see Figure 2-4).
MOUNTING BRACKETS (UNNOTCHED)	128-1631	Standard mounting ear for 19-inch rack applications.
	128-1776	Used for standard (flush) mounting of RA 60, RA 62, or RA 63 in 23-inch rack (see Figure 2-4).
CONNECTORS	142-0422	I/O connector mating plug
	108-0294	I/O connector backshell
FILLER PANELS	RFP 60-1	Covers 1/3 of front panel.
	RFP 60-2	Covers 2/3 of front panel.
ALUMINUM FEET	158-0004	Aluminum feet attach to bottom of rack adapter (set of four).
SCREW	101-0215	Used to attach aluminum feet to rack adapter
SLIDE KIT (preferred)	Kit 219-0433	Slide Kit includes two slides, mounting brackets and attaching hardware; allows rack adapter to be pulled out of rack. Recommended for 18-20 inch setback to intermediate cabinet rail
SLIDE KIT	Kit 219-0442	Slide Kit includes two slides, extended mounting brackets and attaching hardware; allows rack adapter to be pulled out of rack. Recommended for 22-26 inch setback to intermediate or rear cabinet rail if Kit 219-0433 can not be used.
SAFETY COVER, AC	137-0136	Cover source power connections.
SAFETY COVER, DC	137-0135	Cover output power connections.
SCREW	101-0456	Pan head, phillips, self-forming, 6-32 x 1/4 used to attach safety covers.
SUPPORT BRACKET	128-1775	Pair required. Used to provide side support for rack adapter. Requires rear rail at 18-13/16 in. setback.

## SECTION 2 - INSTALLATION

### 2.1 UNPACKING AND INSPECTION

This instrument has been thoroughly inspected and tested prior to packing and is ready for operation. After careful unpacking, inspect for shipping damage before attempting to operate. If any indication of damage is found, file an immediate claim with the responsible transport service. See Table 2-1 for a list of equipment supplied.

**TABLE 2-1. EQUIPMENT SUPPLIED**

ITEM	QUANTITY	PART NUMBER
Rack Adapter	1	RA 60, RA 62, or RA 63
I/O Connector (Mating)	3	142-0422
Instruction Manual	1	243-0848
Split Lockwasher *	6	103-0005
Hex Nut, 5/16-18 *	6	102-0105
* Mounting hardware is assembled to output studs.		

### 2.2 RACK ADAPTER KEYING INSTRUCTIONS

All RA 60 Series rack adapters incorporate a keying mechanism to prevent accidental insertion of the incorrect model HSP power supply into any position. The HSP power supplies are keyed by voltage at the factory. The keying mechanism will prevent engagement of any of the HSP power supply's connectors with those on the rack adapter's intermediate plate unless the key and keyway align. The user can configure each power supply position of the rack adapters for the desired voltage in the desired position; the factory default keying is for the 5-volt HSP module (see Figure 2-1).

The key pins (Kepco P/N 108-0079) used for module keying are located on the intermediate plate (see Figure 2-1) and are accessed through the front of the rack adapter. To alter the keying of any position, simply unscrew the key pin from the intermediate plate using a 1/4" nutdriver or deep socket, reposition key pin at new location and retighten. HSP module keying is identified in Figure 2-1 and in the HSP operator's manual. **DO NOT ALTER THE KEYING AT THE POWER SUPPLY!**

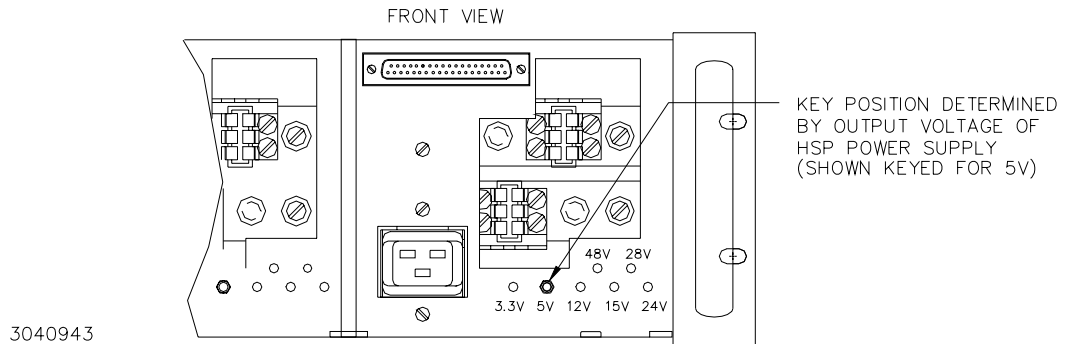

**FIGURE 2-1. KEY PIN LOCATION**

## 2.3 TERMINATIONS

All input, output and control terminations are located on the rear panel of the rack adapter (see Figure 2-2). Other than module keying (Para.2.2), no adjustments or alignments are required.

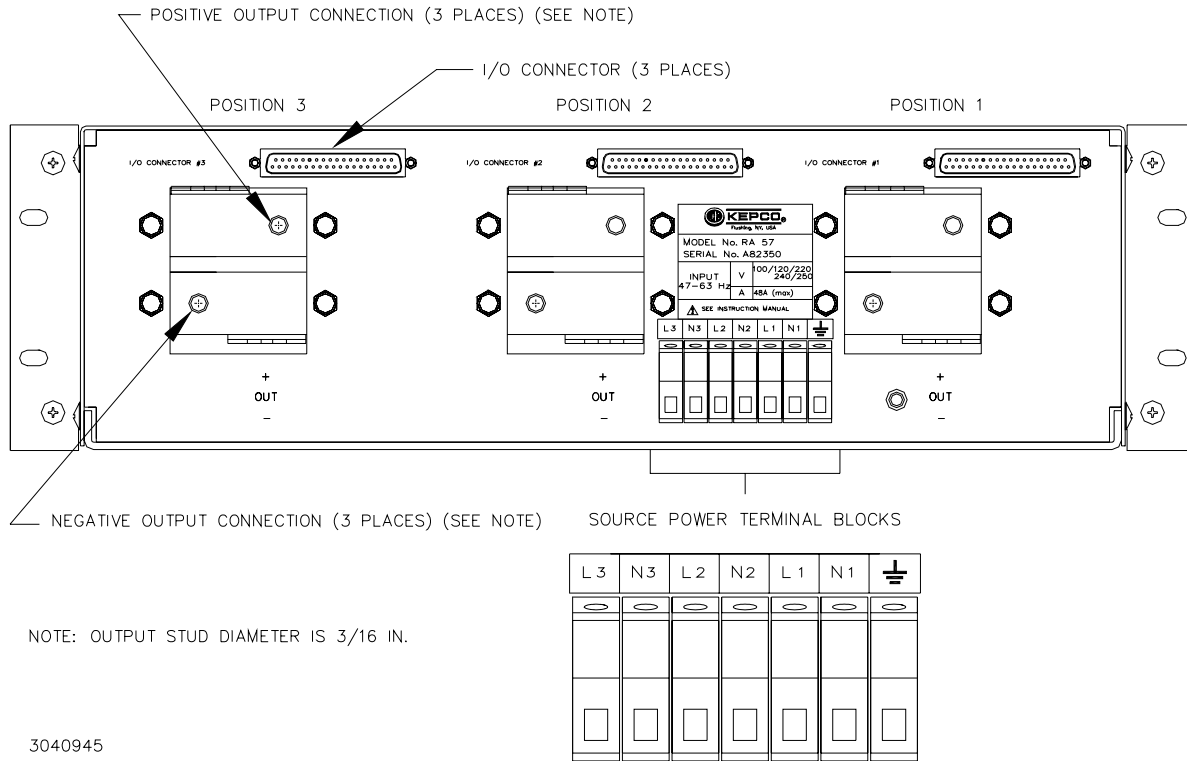

FIGURE 2-2. REAR PANEL CONNECTIONS

## 2.4 SOURCE POWER REQUIREMENTS

When used in conjunction with Kepco HSP series power supplies, these rack adapters can be operated from either single-phase or three-phase a-c source power without adjustment or modification. Voltage and frequency limits are determined by the source power rating of the HSP power supplies. Operation from d-c power is also available; please contact factory for limitations imposed when using d-c source power.

## 2.5 COOLING

The HSP power supplies mounted within the rack adapter are maintained within their operating temperature range by means of internal cooling fans. ALL INLET AND EXHAUST OPENINGS AROUND THE RACK ADAPTER CASE MUST BE KEPT CLEAR OF OBSTRUCTION TO ENSURE PROPER AIR ENTRY AND EXHAUST. Care must be taken that the ambient temperature, which is the temperature of the air immediately surrounding the rack adapter, does not rise above the specified limits for the operating load conditions of the installed HSP power supplies. Kepco recommends providing additional space above and below the rack adapter where possible when the rack adapter is fully populated.



**2.6 INSTALLATION** (Refer to "Mechanical Outline Drawing," Figure 1-2.

RA 60 Series rack adapters are designed for rack-mounted applications. The rack adapter will mount directly to EIA standard 19" racks; optional mounting ears are available to provide for mounting to EIA standard 23" and 24" racks (see Figure 2-3 and Table 1-2). Other fixed mounting applications are possible; consult factory for details.

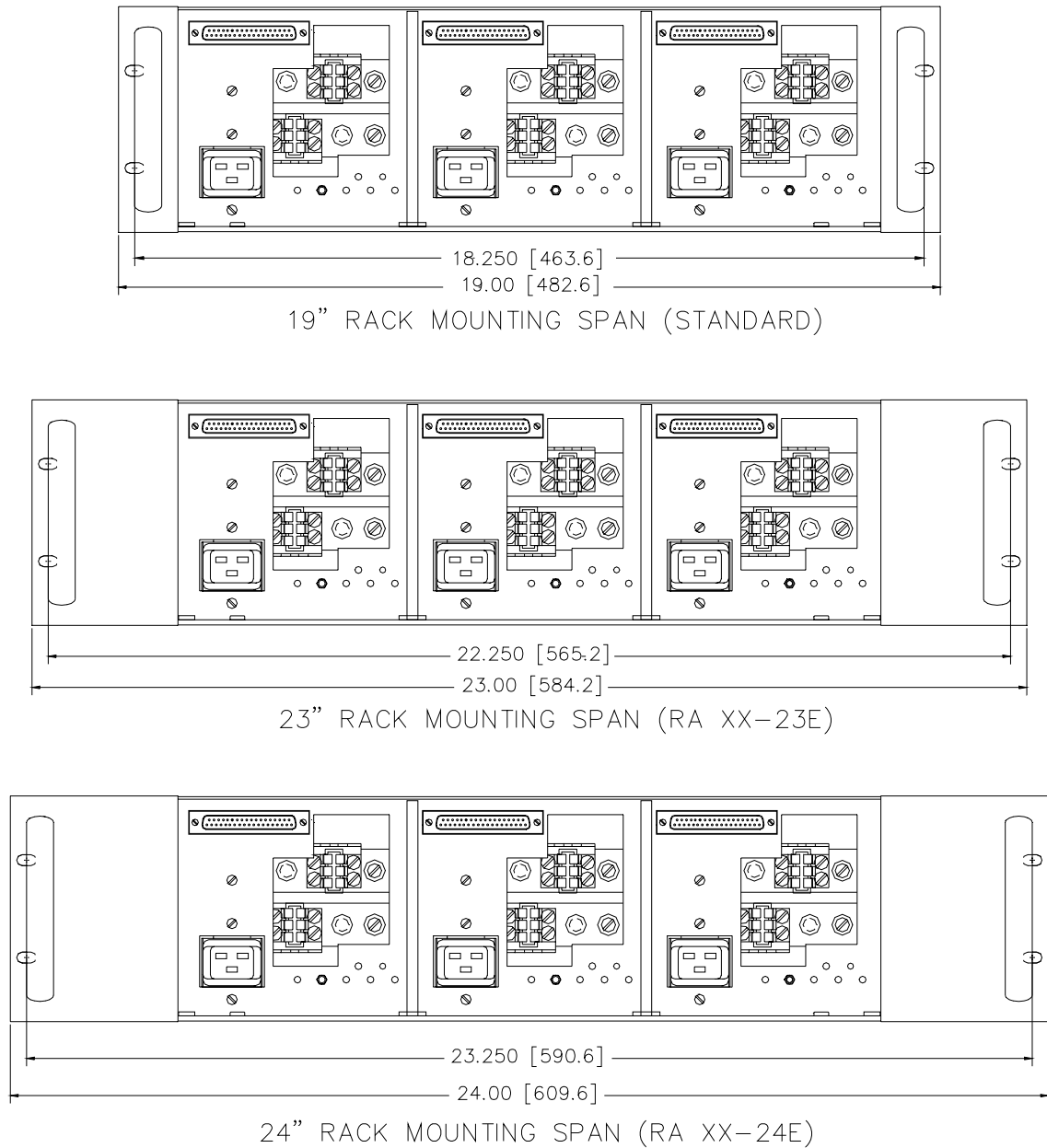

3040946

**FIGURE 2-3. MOUNTING DIMENSIONS**

- (a) When used in fixed rack-mounted applications, the rack adapter is attached to the rack via the two mounting ears; two screws are required per mounting ear for proper support.
- (b) The rack adapter can be attached to the rack using chassis slides; the rack adapter sides are predrilled for 18" (457.2mm) chassis slides (see Table 1-2).
- (c) For applications which require less depth protrusion of the rack adapter within the rack, the rack adapters provide two "set-back" positions for use with optional notched mounting ears (see Tables 1-1 and 1-2); see Figure 2-4 for set-back dimensions.

For all installations provide adequate clearance around air inlet and exhaust locations and ensure that the temperature immediately surrounding the unit, and especially near the air inlets, does not exceed the maximum specified ambient temperature for the operating conditions of the installed power supplies.

**CAUTION**

**WHEREVER POSSIBLE RACK ADAPTER SHOULD BE MOUNTED BEFORE INSTALLING POWER SUPPLIES TO AVOID DISTORTION OF THE RACK ADAPTER (INSTALL POPULATED RACK ADAPTER ONLY IF BOTTOM OF RACK ADAPTER IS FULLY SUPPORTED). FAILURE TO OBSERVE THIS CAUTION MAY RESULT IN MISALIGNMENT OF THE POWER SUPPLIES WITH THE RACK ADAPTER.**

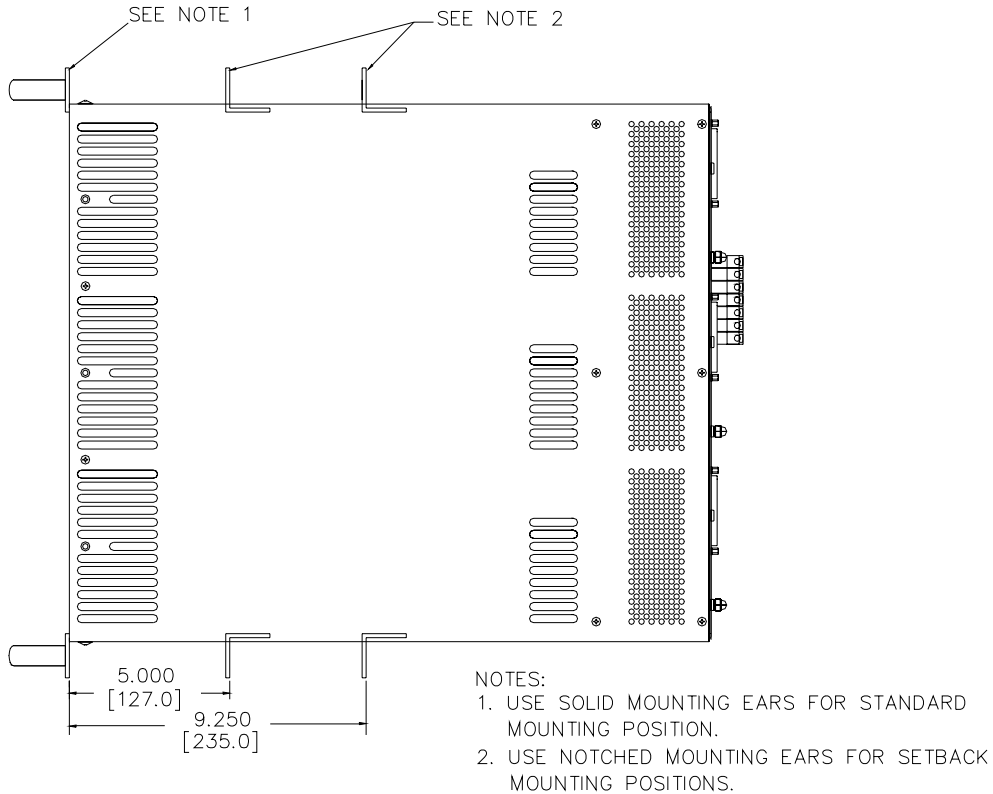

3040947

**FIGURE 2-4. SET-BACK DIMENSIONS**

## 2.6.1 MOUNTING EAR INSTALLATION

If mounting ears are removed, or optional mounting ears are purchased to allow installation in a different size rack, install each standard (unnotched) mounting ear with spacer (part number 128-1716) between the mounting ear and the inside surface of the rack adapter chassis (see Figure 2-5). Attach mounting ear to chassis using the two screws and two lockwashers provided.

Installation of the notched mounting ears is similar to the above procedure, except the notched flange is first inserted in the slot on the rack adapter chassis, then rotated 90 degrees while the spacer is inserted between the mounting ear flange and the inside surface of the rack adapter chassis (see Figure 2-5).

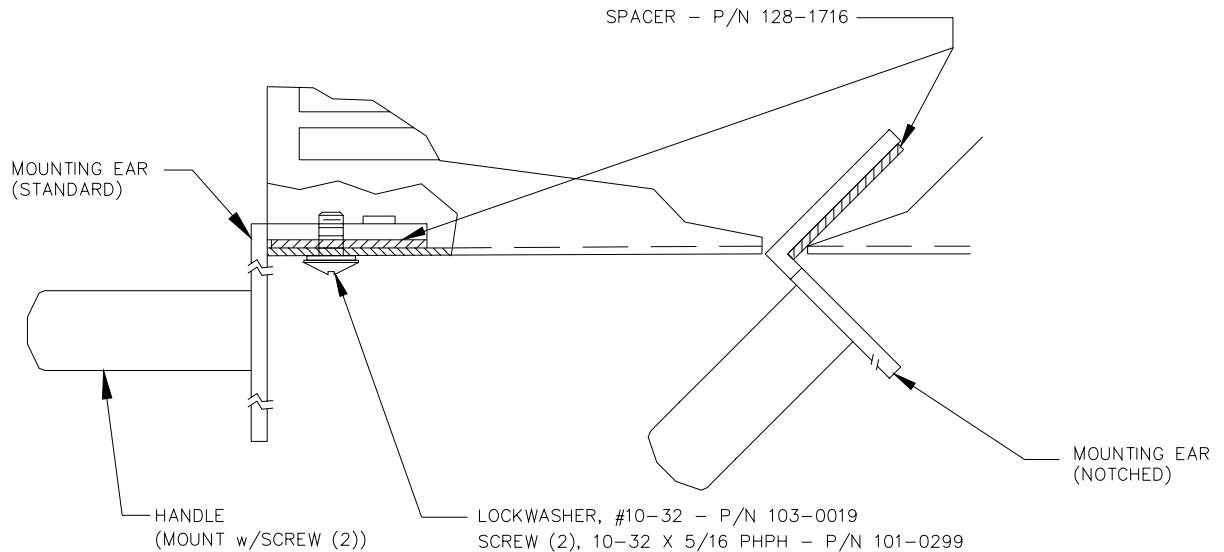

3040944

FIGURE 2-5. MOUNTING EAR INSTALLATION

## 2.7 WIRING INSTRUCTIONS

Interconnections between an a-c power source and a stabilized power supply, and between the power supply and its load are as critical as the interface between other types of electronic equipment. If optimum performance is expected, certain rules for the interconnection of source, power supply and load must be observed by the user. These rules are described in detail in the following paragraphs and in the operating instructions for HSP Series power supplies.

### 2.7.1 SAFETY GROUNDING

Local, national and international safety rules dictate the grounding of the metal cover and case of any instrument connected to the a-c power source, when such grounding is an intrinsic part of the safety aspect of the instrument. The instructions below suggest wiring methods which comply with these safety requirements; however, in the event that the specific installation for the power system involves differences with the recommended wiring, it is the customer's responsibility to ensure that all applicable electric codes for safety grounding requirements are met.

### 2.7.2 SOURCE POWER CONNECTIONS

The rear panel of RA 60 Series rack adapters (Figure 2-2) includes seven terminal blocks to allow for connection of single-phase a-c, three-phase a-c (4-wire or 5-wire) and d-c input power. These terminal blocks are labeled L1, N1, L2, N2, L3, N3, and G. Each terminal block will accommodate up to #6 AWG (16mm<sup>2</sup>) or equivalent conductor size. Their functions are as follows:

- **Terminal G** is the safety ground connection for the rack adapter, and is connected to the rack adapter chassis as well as to the safety ground terminal of the source power connector of each of the three power supply mounting positions. Regardless of the type of source power provided, Terminal G must be connected to safety ground in order to ensure proper grounding of the HSP power supplies when installed. The conductor used to connect Terminal G to safety ground must be sized to support the total fault current of all of the power supplies installed in the rack adapter; for HSP series power supplies, the ground fault current rating is 20 amperes per power supply. Consult local electric codes for the proper wire size to carry the required fault current.
- **Terminal pairs L1/N1, L2/N2, L3/N3** are connected to the high-side and low-side contacts of the source power connectors for each of the three power supply mounting positions (1, 2 and 3) of the rack adapter (see Figure 2-2). Each terminal pair (Lx/Nx) is isolated from the remaining two pairs, facilitating redundant source power connections if desired. The conductor used to connect terminals Lx and Nx to source power must be sized for the 16 ampere maximum source current drawn by HSP Series power supplies; Kepco recommends #14 AWG (2.5mm<sup>2</sup>) or equivalent minimum conductor size to support this current.

### 2.7.3 SOURCE POWER CONFIGURATIONS

The following standard wiring configurations are recommended by Kepco as being compliant with national and international safety standards. It is the user's responsibility to ensure that all applicable local electric codes are met. The minimum and maximum limits for source power voltage are defined in HSP series power supply specifications.

#### CAUTION

**UNDER NO CIRCUMSTANCES SHOULD THE STEADY-STATE SOURCE VOLTAGE  
APPLIED ACROSS ANY Lx/Nx PAIR EXCEED 277V rms!**

### 2.7.3.1 A-C SOURCE POWER, SINGLE PHASE

For single-phase a-c source power, connect Terminal G of the rack adapter to source power safety ground; then connect a separate wire pair from the power source to each Lx/Nx terminal block pair to be populated by an HSP power supply (see Figure 2-6).

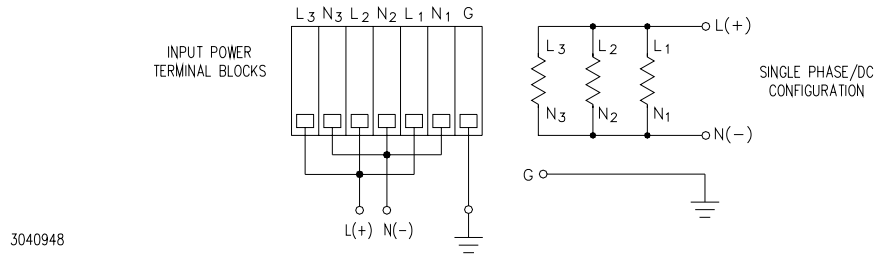

FIGURE 2-6. SINGLE PHASE A-C/D-C SOURCE POWER WIRING

If desired, a single wire pair can be run from the power source to any Lx/Nx pair, with jumpers connecting the remaining Lx/Nx pairs to the first pair; however, the wires must be adequately rated to support the total current being delivered through them. For the example shown in Figure 2-6, the jumper wires are sized for 16 amps, but the source wires must be sized for 3 times 16 amps, or 48 amps.

### 2.7.3.2 A-C SOURCE POWER, THREE PHASE

Three-phase a-c source power from either delta- or wye-configuration power sources can be used. When using wye-configuration power, the user should configure the power system so as to balance the load drawn from each phase to minimize the current flow in the source power neutral wire whenever possible. When possible, the user should wire the rack adapter in accordance with the instructions for delta power in order to take advantage of the lower input current requirements. Regardless of the source power configuration, Terminal G of the rack adapter must be connected to safety ground.

- **Delta Power** - Connect a separate wire pair from each Lx/Nx pair on the rack adapter across successive line terminals of the source power (e.g., A-B, B-C, C-A) (see Figure 2-7).

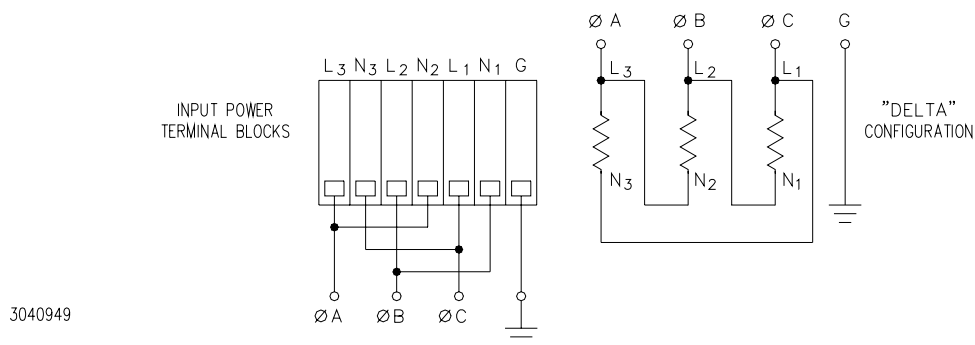
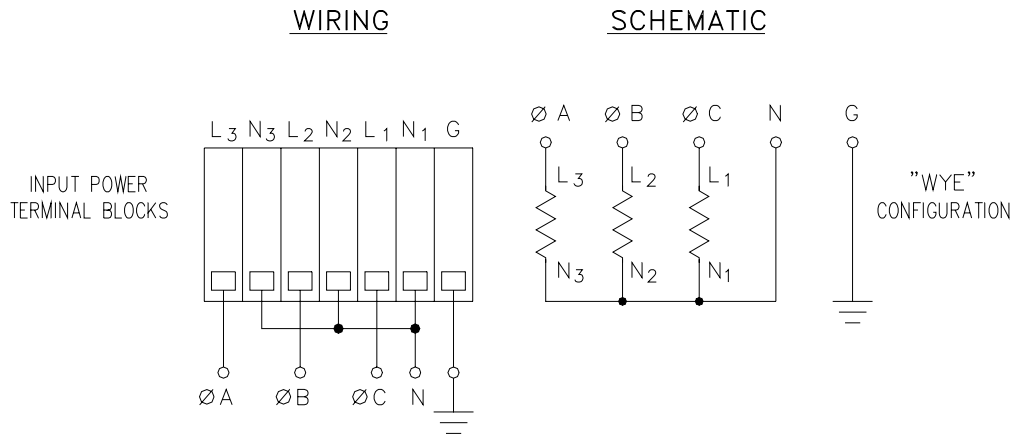

FIGURE 2-7. THREE PHASE DELTA A-C SOURCE POWER WIRING

- **Wye Power** - Connect a separate wire pair from each Lx/Nx pair on the rack adapter to line and neutral terminals of the power source, using successive line terminals (e.g., A-N, B-N, C-N) (see Figure 2-8)



3040950

**FIGURE 2-8. THREE PHASE WYE A-C SOURCE POWER WIRING**

### 2.7.3.3 D-C SOURCE POWER

For d-c source power, wire the rack adapter in accordance with the instructions for single-phase a-c power per Para. 2.7.3.1. Contact Kepco Applications Engineering for additional restrictions imposed by d-c source power.

### 2.7.4 CONTROL SIGNAL CONNECTIONS

Access to the control signal (I/O) connector for each HSP power supply is provided via the three 37-pin D-subminiature connectors on the rear panel of the rack adapter (see Figure 2-2). Three mating connectors (Kepco PN 142-0422) are provided in a plastic bag. These connectors are simply extensions of the identical connectors located on the HSP power supplies. Consult the HSP operator's manual for instructions on wiring and use of these control lines.

### 2.7.5 OUTPUT LOAD CONNECTIONS

Load connections to the rack adapters are achieved via the stud pairs located on the rear panel directly behind each mounting position (see Figure 2-2). Required hardware for attaching output cables are assembled to the output studs. RA 60 rack adapters provide permanent interconnection of the three power supply positions for parallel/redundant configuration. All three load connections must be used when the 3.3 volt and 5 volt modules are used. RA 62 and RA 63 rack adapters employ a modular bus bar system to permit a variety of load configurations. The following sections describe the basic output bus bar configurations available with Series RA 60 rack adapters. Additional information regarding these and other load interface requirements are contained in the HSP operator's manual.

NOTE!

**REGARDLESS OF OUTPUT CONFIGURATION, OUTPUT SENSE LINES MUST BE PROPERLY CONNECTED FOR OPERATION (REFER TO HSP OPERATOR'S MANUAL).**

### **2.7.5.1 PARALLEL/REDUNDANT OPERATION**

RA 60 and RA 62 rack adapters provide permanently configured outputs for parallel/redundant operation: all three positions for RA 60, positions 1 and 2 for RA 62. Load wiring is attached to the rack adapter at the output studs. Although load wiring can be attached to any single position, Kepco strongly recommends distributing the load interface evenly among the populated power supply positions to minimize load sharing error; in no case should load current drawn from any one terminal exceed 300 Amperes. Consult HSP operator's manual for additional information regarding parallel/redundant load operation.

### **2.7.5.2 SERIES/INDEPENDENT OPERATION**

RA 63 rack adapters can be used for either independent or series operation of HSP power supplies. For series operation, install a jumper cable from the negative bus bar of one independent position to the positive bus bar of the adjacent independent position for as many positions as required. Consult the HSP operator's manual for additional information regarding series operation. The RA 60 cannot be used for series operation except when connecting consecutive rack adapters in series; contact Kepco Applications Engineering for additional information.

## **2.8 SHIPPING**

Shipping of the rack adapter is recommended *only* after the HSP power supplies have been removed from the rack adapter. Contact Kepco Applications Engineering if further assistance is required.

